

GEARBOX HD295

Servogear HD295 gearbox is available as H-gear configuration, U-gear configuration and PTI-gear configuration.

A special upside down configuration can be supplied for H-gear configuration and PTI hybrid drive. The upside down configuration is specially adapted for the SWATH` s.

The H-gear configuration can only be as a freestanding gearbox. The gearbox can be supplied with a possibility to run a primary driven non clutchable PTO pump rated at max 460 Nm.



TECHNICAL SPECIFICATIONS

CONFIGURATION	KW/ RPM	TORQUE (NM)	STANDARD REDUCTION RATIOS	WEIGHT (dry, approx.kg)
U-drive	0,600	5730	2,742 : 1 and 3,296 : 1	1220/1080
	0,475	4548	4,20 : 1	
	0,523	5002	4,20 : 1	
H-drive	0,600	5730	2,742 : 1 and 3,296 : 1	1220/1080
	0,475	4548	4,20 : 1	
	0,523	5002	4,20 : 1	
PTI-drive	1,200	2 x 5730	2,742 : 1 and 3,296 : 1	1370/1330
	0,953	2 x 4548	4,20 : 1	
	1,048	2 x 5002	4,20 : 1	

DIMENSIONS FOR H-DRIVE(MM)

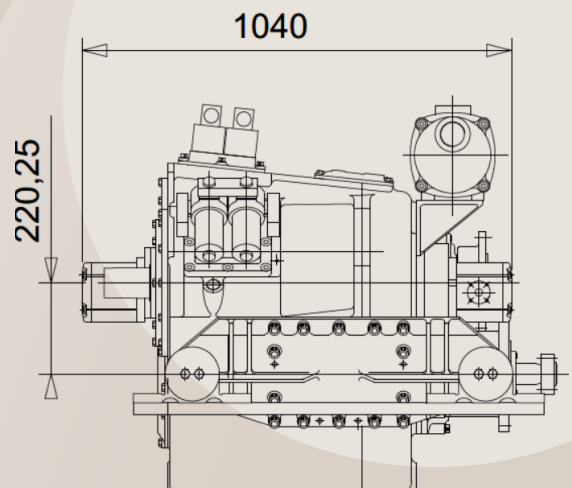
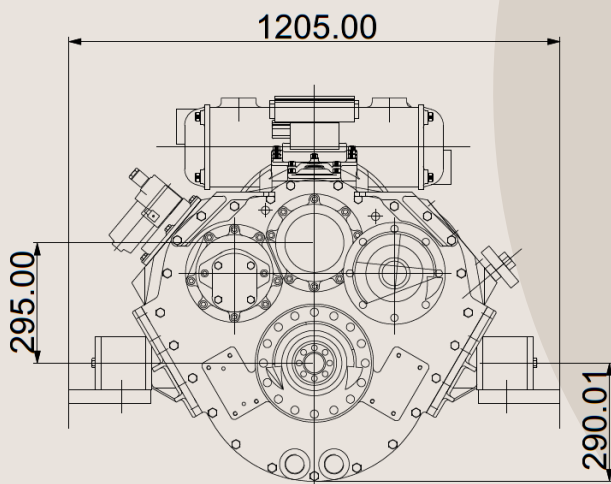

* Dimensions for H-drive